

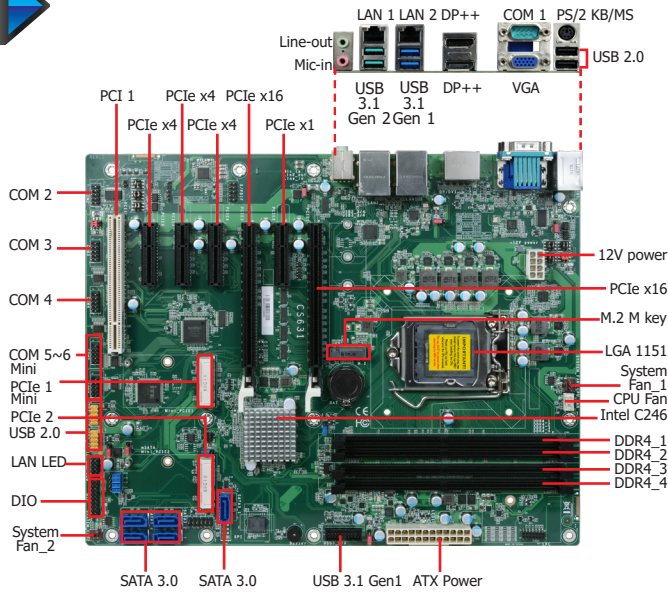

# CS631-C246

Workstation

C246



## Features

- 4 DDR4 ECC/Non-ECC DIMM up to 128GB
- 3 independent displays: VGA + DP++ + DP++
- DP++ resolution up to 4096x2160 @ 60Hz
- Multiple expansion: 2 PCIe x16 (1 x16 signal or 2 x8 signals), 3 PCIe x4, 1 PCIe x1, 1 PCI, 2 Full-sized Mini PCIe, 1 M.2 M key
- Rich I/O: 2 Intel GbE, 6 COM, 2 USB 3.1 Gen 2, 4 USB 3.1 Gen 1, 6 USB 2.0



## 2 Extension Modules for Additional 4 COM Ports (via the LPC connector)

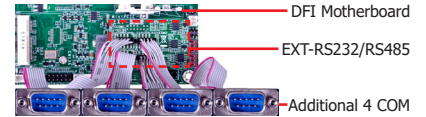
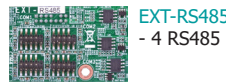
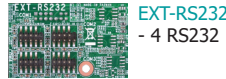

## Ordering Information

Model Name	P/N	Memory	GbE	RS-232/422/485	RS-232	USB3.1 Gen 2	USB3.1 Gen 1	USB 2.0	TPM 2.0	Power	Thermal	Temp.
CS631-C246CRM	770-CS6311-000G	4 DIMM	2	2	4	2	4	6	0	24-pin ATX	Active	0 to 60°C
CS631-C246CRM	770-CS6311-200G	4 DIMM	2	2	4	2	4	6	1	24-pin ATX	Active	0 to 60°C

## Mechanical Drawing

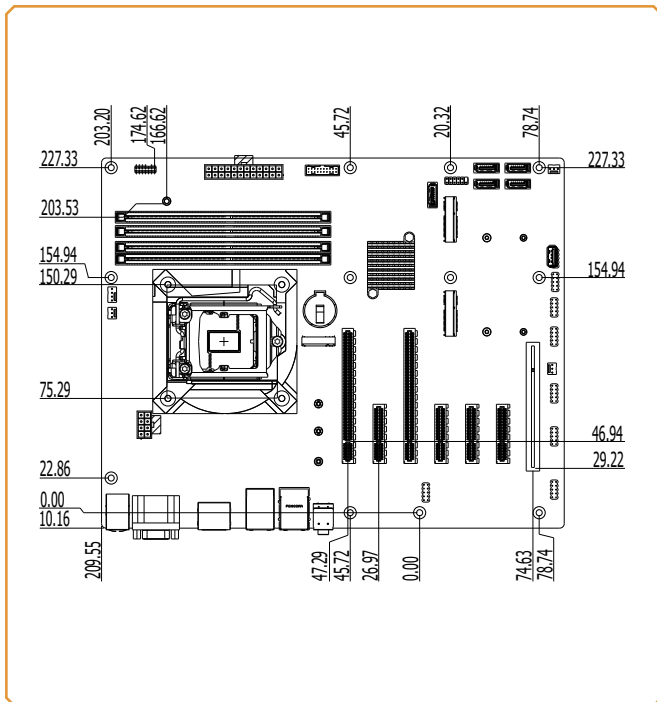

## Block Diagram

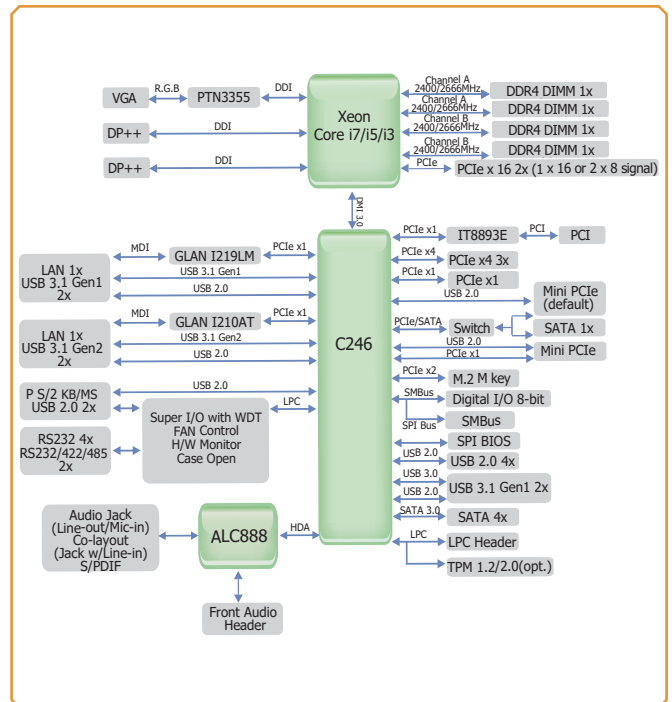

## Specifications

<b>SYSTEM</b>	<b>Processor</b>	8th Generation Intel® Core™ / Pentium® / Celeron® LGA 1151 Socket Processors: Intel® Xeon® E-2176G (6 Cores, 12M Cache, up to 4.7 GHz); 80W Intel® Xeon® E-2124G (4 Cores, 8M Cache, up to 4.5 GHz); 71W Intel® Core™ i7-8700 (6 Cores, 12M Cache, up to 4.6 GHz); 65W Intel® Core™ i7-8700T (6 Cores, 12M Cache, up to 4.0 GHz); 35W Intel® Core™ i5-8500 (6 Cores, 9M Cache, up to 4.1 GHz); 65W Intel® Core™ i5-8500T (6 Cores, 9M Cache, up to 3.5 GHz); 35W Intel® Core™ i3-8100 (4 Cores, 6M Cache, 3.6 GHz); 65W Intel® Core™ i3-8100T (4 Cores, 6M Cache, to 3.1 GHz); 35W Intel® Pentium® G5400 (2 Cores, 4M Cache, 3.7 GHz); 58W Intel® Pentium® G5400T (2 Cores, 4M Cache, 3.1 GHz); 35W Intel® Celeron® G4900 (2 Cores, 2M Cache, 3.1 GHz); 54W Intel® Celeron® G4900T (2 Cores, 2M Cache, 2.9 GHz); 35W 9th Generation Intel® Core™ LGA 1151 Socket Processors: Intel® Xeon® E-2278GEL (8 Cores, 16M Cache, up to 3.9 GHz); 35W Intel® Xeon® E-2226GE (6 Cores, 12M Cache, up to 4.6 GHz); 80W Intel® Core™ i7-9700TE (8 Cores, 12M Cache, up to 3.8 GHz); 35W Intel® Core™ i5-9500E (6 Cores, 9M Cache, up to 4.2 GHz); 65W Intel® Core™ i5-9500TE (6 Cores, 9M Cache, up to 3.6 GHz); 35W Intel® Core™ i3-9100E (4 Cores, 6M Cache, 3.7 GHz); 65W Intel® Core™ i3-9100TE (4 Cores, 6M Cache, to 3.2 GHz); 35W
	<b>Chipset</b>	Intel® C246 Chipset
	<b>Memory</b>	Four 288-pin ECC/Non-ECC DIMM up to 128GB (Core™ i5/i7 only support non-ECC) Dual Channel DDR4 2400/2666MHz
	<b>BIOS</b>	AMI SPI 128Mbit
<b>GRAPHICS</b>	<b>Controller</b>	Intel® HD Gen 9 Graphics
	<b>Feature</b>	OpenGL 5.0, DirectX 12, OpenCL 2.1 HW Decode: AVC/H.264, MPEG2, VC1/WMV9, JPEG/MJPEG, HEVC/H265, VP8, VP9 HW Encode: MPEG2, AVC/H264, JPEG, HEVC/H265, VP8, VP9
	<b>Display</b>	1 x VGA 2 x DP++ VGA: resolution up to 1920x1200 @ 60Hz DP++: resolution up to 4096x2160 @ 60Hz
	<b>Triple Displays</b>	VGA + DP++ + DP++
<b>EXPANSION</b>	<b>Interface</b>	2 x PCIe x16 (Gen 3) (1 x16 signal or 2 x8 signals) 3 x PCIe x4 (Gen 3) 1 x PCIe x1 (Gen 3) 1 x PCI 2 x Full-sized Mini PCIe (1* PCIe/SATA/USB2.0, 1* PCIe/USB2.0) 1 x M.2 2242/2260/2280 M key (PCIe Gen3 x 2 NVMe)
<b>AUDIO</b>	<b>Audio Codec</b>	Realtek ALC888
<b>ETHERNET</b>	<b>Controller</b>	1 x Intel® I210AT PCIe (10/100/1000Mbps) 1 x Intel® I219LM PCIe with iAMT12.0 (10/100/1000Mbps) (only Xeon, Core i7/i5 supports iAMT)
<b>REAR I/O</b>	<b>Ethernet</b>	2 x GbE (RJ-45)
	<b>USB</b>	2 x USB 3.1 Gen2 2 x USB 3.1 Gen1 2 x USB 2.0
	<b>Serial</b>	1 x RS-232/422/485 (RS-232 w/ power) (DB-9)
	<b>PS/2</b>	1 x PS/2 (mini-DIN-6)
	<b>Display</b>	1 x VGA 2 x DP++
	<b>Audio</b>	1 x Line-out, 1 x Mic-in, 1 x Line-in (opt., MOQ required)
	<b>INTERNAL I/O</b>	<b>Serial</b>
<b>USB</b>		2 x USB 3.1 Gen 1 (2.00mm pitch) 4 x USB 2.0 (2.54mm pitch) (1 x USB 2.0 colay vertical Type A) (opt., MOQ required)
<b>Audio</b>		1 x Front Audio Header 1 x S/PDIF
<b>SATA</b>		5 x SATA 3.0 (up to 6Gb/s, 1 SATA shared with mini PCIe (SATA), default at mini PCIe) RAID 0/1/5/10
<b>DIO</b>		1 x 8-bit DIO
<b>LPC</b>		1 x LPC (supports LPC EXT-RS232/RS485 module)
<b>SMBus</b>		1 x SMBus
<b>WATCHDOG TIMER</b>		<b>Output &amp; Interval</b>
<b>SECURITY</b>	<b>TPM</b>	Infineon TPM1.2/2.0 (opt., MOQ required)
<b>POWER</b>	<b>Type</b>	ATX
	<b>Connector</b>	8-pin ATX 12V power 24-pin ATX power
	<b>Consumption</b>	Typical: i7-8700K: 3.3V @ 0.36A (1.188Watt); 5V @ 0.53A (2.65Watt); 12V @ 0.35A (4.2Watt) Max.: i7-8700K: 3.3V @ 0.65A (2.145Watt); 5V @ 1.44A (7.2Watt); 12V @ 10.59A (127.08Watt)
	<b>RTC Battery</b>	CR2032 Coin Cell
<b>OS SUPPORT</b>		Windows 10 IoT Enterprise 64-bit Linux
<b>ENVIRONMENT</b>	<b>Temperature</b>	Operating: 0 to 60°C Storage: -30 to 60°C with RTC Battery; -40 to 85°C without RTC Battery
	<b>Humidity</b>	Operating: 5 to 90% RH Storage: 5 to 90% RH
	<b>MTBF</b>	536,604 hrs @ 25°C; 299,525 hrs @ 45°C; 185,098 hrs @ 60°C Calculation model: Telcordia Issue 4 Environment: GB, GC – Ground Benign, Controlled
<b>MECHANICAL</b>	<b>Dimensions</b>	ATX Form Factor 305mm (12") x 244mm (9.6")
	<b>Height</b>	PCB: 1.6mm Top Side: 38.5mm Bottom Side: 4.4mm
<b>CERTIFICATIONS</b>		CE, FCC Class B, RoHS

### ▶ Packing List

• 1 CS631-C246 motherboard	
• 1 COM port cables (Length: 300mm, 2 x COM ports)	A81-015026-023G
• 1 Serial ATA data cable (Length: 500mm)	332-553001-005G
• 1 I/O shield	A49-CS6310-000G
• 1 M.2 2242/2260/half mini PCIe standoff	A33-725019-090G
• 1 M.2 screw	A32-112016-041G
• 1 mini PCIe screw	A32-112016-041G

### ▶ Optional Items

• USB 2.0 port cable (Length: 350mm)	A81-001066-016G
• USB 3.1 Gen1 port cable (Length: 320mm)	A81-001052-023G
• COM port cable (Length: 300mm, 2 x COM ports)	A81-015026-023G
• Serial ATA data cable (Length: 500mm, W/LOCK)	332-553001-005G
• Thermal solution (For 35W, Height: 37.3mm)	A71-101107-000G
• Thermal solution (For 65W, Height: 74.47mm)	A71-101158-000G
• Thermal solution (For 95W, Height: 77.2mm)	761-103001-000G
• LPC EXT-RS232 module (4 x RS232 ports)	770-EXTRS1-000G
• LPC EXT-RS485 module (4 x RS485 ports)	770-EXTRS1-100G
• DP to HDMI dongle	612-D2H13M-000G